

Oxygen Analyzer Manual

Model 2001RS

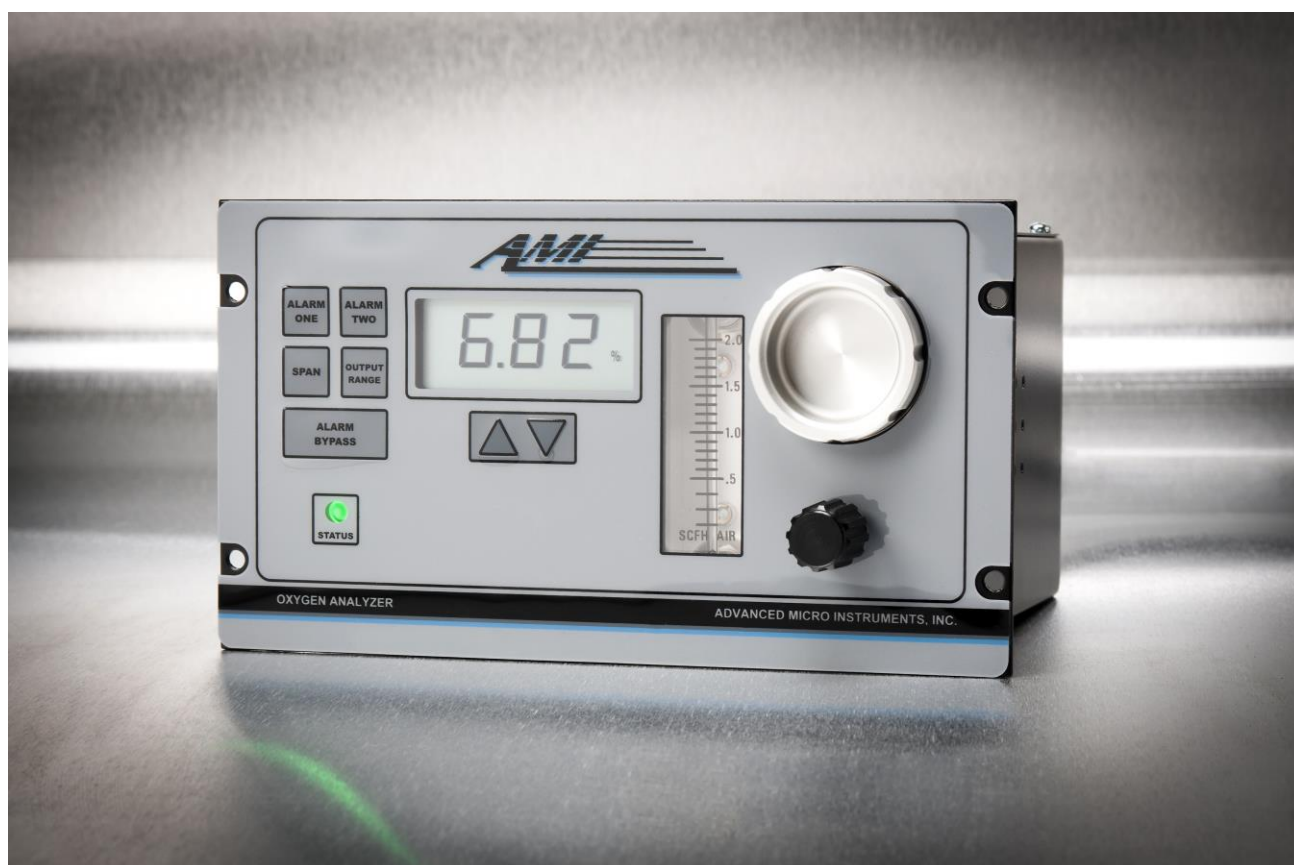

AMI, Costa Mesa, CA

Contents

Preface	1
Caution	1
Address	1
Model 2001RS Oxygen Analyzer	2
Introduction	2
Features:	2
Oxygen sensor:	3
Sensor Warranty:	3
Instrument Warranty:	3
Important:	4
-----Points to consider first! -----	4
Installation and Operation	6
Receiving the analyzer	6
Installation.	6
Location:	6
Short-form Installation Procedure	8
Laptop set up procedure:	11

Detailed Analyzer Description	12
Front Panel	12
Calibrate (“Span”) the analyzer:	13
LCD display:	13
Analog output:	13
Alarms:	14
Digital outputs:	15
Alarm Bypass:	15
LED:	15
Up button - Span Factor:	16
Down button – Temperature reading:	16
Back Panel	17
AC power	17
Serial Communications:	17
Sample Handling:	19
Operation	20
General Information	20
Basic knowledge about oxygen measurement	20
Analyzer operation	21
Sample tubing and components	21
Leaks	21
Exhaust	21
Calibrating the analyzer	22
Using the analyzer	24
Output Range	24
Security:	24
Advanced Features	24
Maintenance and troubleshooting	25
Maintenance:	25

Periodic Calibration:	25
Sensor Replacement:	25
Sensor replacement procedure:	26
Bleeding a regulator	27
Troubleshooting	28
All oxygen applications	28
Specifications and Disclaimer	31
Specifications:	31
Disclaimer	32

Preface

The AMI 2001RS provide the latest in high-definition oxygen analysis. It analyzes the oxygen content of gas samples to trace levels, using AMI-manufactured oxygen sensors and advanced high definition electronics for noise and interference free performance. It is intended for use in general purpose environments. Several aspects of the design are the subject of patents, number 5,728,289 and 6,675,629; the sensors are also covered by a patent, number 7,316,768.

Please verify that the analyzer was not damaged in transit. If so please contact the shipper as well as AMI.

Trace Oxygen measurement is difficult because the air contains 20.9% (209,000ppm) of oxygen, and it can get into a pressurized pipeline through the smallest leaks. Oxygen molecules will enter through a leak, no matter the pressure or the nature of the gas in the line. This analyzer is an exceptionally sensitive leak detector – including those provided by improper installation. Make sure you read this manual carefully prior to installation.

Caution

Read and understand this manual fully before attempting to use the instrument. In particular understand the hazards associated with using flammable or poisonous gases.

Address

Advanced Micro Instruments

225 Paularino Ave

Costa Mesa, CA 92626

(714) 848-5533

www.AMIO2.com

Last Revised: 08/31/2018

Model 2001RS Oxygen Analyzer

Introduction

The Advanced Micro Instrument Oxygen Analyzer Model 2001R Series provides the latest in high precision oxygen measurement. It is designed for monitoring oxygen in trace (ppm) ranges in a non-hazardous area, in virtually any background gas.

This manual is divided into two major sections: a quick reference section for experienced users, and a detailed exploration of all the many features of the analyzer for all users.

This manual covers software version 5.23.

Features:

- 10 user selectable output ranges
- 3 ½ digit LCD
- 2 fully adjustable oxygen concentration alarms
- Alarm hold off/Bypass
- RFI protected
- 4-20mA. isolated analog output
- ❖ Analog output calibration synchronizes the analog output with an external monitoring system
- ❖ Data logger
- ❖ Fully programmable alarm delays
- ❖ USB port for configuration and access to advanced features
- ❖ Calibration history and sensor usage logging
- ❖ Power brownout and power failure logging
- Modbus using Bidirectional RS485 for industry-standard communications
- Low minimum detection limit 0.05ppm
- Excellent repeatability
- Extended operating temperature range
- Fast upscale/downscale response times
- Patented Cellblock Technology: Allows for all components such as flow control valve, flow meter, Sample, span and seal-off solenoid valves and compression fittings to be an integral part of the cellblocks, eliminating long lengths of tubing and fittings.
 - Benefits of this design include compact size, faster response times and front panel sensor access without the need for tools.
- Unaffected by changes in flow rate from 0.1 to 2.0 SCFH
- Panel mount
- Compact size
- 2 year warranty for analyzer, parts and labor
- 6 month sensor warranty, life expectancy 1-2 years
- ❖ Requires optional AMI User Interface software

Oxygen sensor:

AMI manufactures its own electrochemical sensor. This measures the concentration of oxygen in a gas stream, using an oxygen specific chemistry. It generates an output current in proportion to the amount of oxygen present, and has zero output in the absence of oxygen, thus avoiding any requirement to zero the analyzer. The cell is linear throughout its range. The span calibration may be performed using standard span gases or ambient air. Unlike competitive sensors, the AMI sensor is made using a high capacity metallic body that provides long life with about twice the active ingredients of conventional sensors, but with much faster come-down times – typically under twenty minutes to 10ppm from a 1 minute air exposure.

Sensor Warranty:

The sensor is warranted to operate for a period determined by its class. If the sensor ceases to operate correctly before this time has elapsed, contact AMI for a return authorization for evaluation. If there is any evidence of defective material or workmanship the sensor will be replaced free of charge.

NOTE: Any evidence of abuse or physical damage, such as a torn membrane, will void the warranty.

Instrument Warranty:

Any failure of material or workmanship will be repaired free of charge for a period of two years from the original purchase (shipping date) of the instrument. AMI will also pay for one way shipment (back to the user).

This warranty does not cover the sensor, which is covered by its own warranty (see above).

Any indication of abuse or tampering will void the warranty.

Important:

This section contains important information to do with safety and installation. Please don't skip it!

Do not open the sealed metallized T-2 or T-4 oxygen sensor bag or install the sensor until the analyzer is completely installed, the gas lines are plumbed and the electrical connections are all made; and sample or zero gas is ready to flow into it. If you do you will expose the sensor to so much oxygen in the air that it will be saturated and may not come down to low levels for a very long time.

-----Points to consider first! -----

Environment – This analyzer is intended for use in a control room environment, with a temperature range of 41°F to 113°F.

Sample conditions – if your sample is hot and wet, you will need to keep water from condensing in the sample line or analyzer. Contact AMI for advice. If the sample contains high amounts of CO₂, it may be necessary to temperature control the analyzer so that the sensor is not affected by CO₂ coming out of solution as the temperature increases. Contact AMI for this one too.

Power supply – The unit contains a switching power supply that is insensitive to AC voltage or frequency changes over a wide range. It will work with any normal UPS system if desired.

Electrical connections - Following best electrical practices, run the analog output connections separately from the power and alarm connections. Modbus communications if used should be run with the analog output wiring, using twisted pair wires for both circuits. Run the alarm wires in the same conduit as the power wires.

Span gas – if you are going to use span gas to calibrate the analyzer as opposed to air, you will need to plumb a span gas tank to the span inlet on the back of the analyzer. When you do this, the line to the tank will be full of air. It is imperative that you bleed the regulator on the span gas tank, and that you flush the line. However when you subsequently span the analyzer, oxygen from the air will have leaked into the span line increasing its oxygen content. If this is such as to send the oxygen reading up into the percent levels, perform the span operation twice – the first time to flush the air out, and

the second time after you've let the sensor come back down to low levels. Wait until the reading has recovered, and then start the span function again, and this time actually adjust the span.

Installation and Operation

Receiving the analyzer

When you receive the instrument, check the package for evidence of damage and if any is found, contact the shipper.

Do not open the sealed metallized T-2 or T-4 oxygen sensor bag or install the sensor until the analyzer is completely installed, the gas lines are plumbed and the electrical connections are all made; and sample or a suitable low oxygen level gas such as nitrogen or a low level span gas is ready to flow into it.

Installation.

Location:

The unit is designed to be mounted in a panel in a general purpose area. It should be mounted at a suitable viewing level. Refer to the drawing (figure 1) showing the analyzer dimensions. It is not suitable for use in a hazardous area.

Although the unit is RFI protected, do not to mount it close to sources of electrical interference such as large transformers, motor start contactors, relays etc. Also avoid subjecting it to excessive vibration – anything worse than a truck may be problematical.

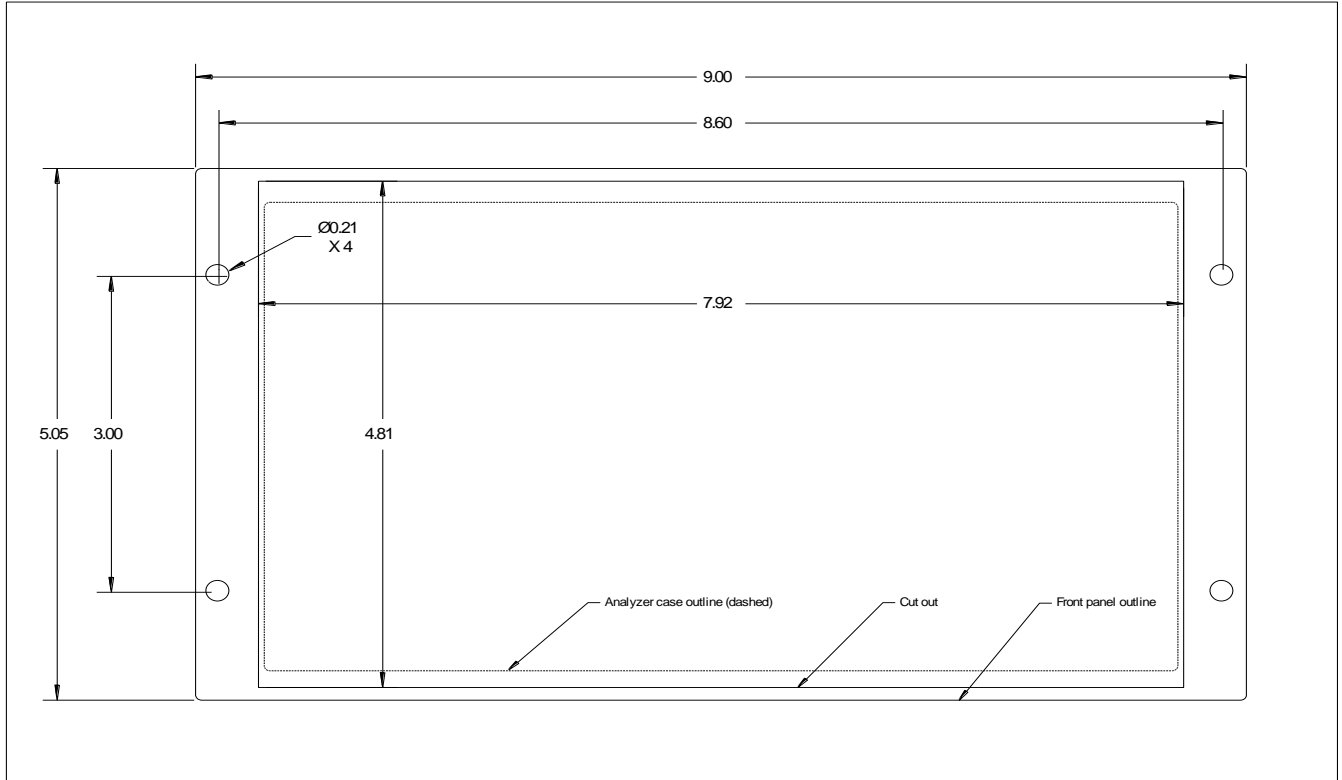

Figure 1. Outline and Cut Out Drawing

Short-form Installation Procedure



Figure 2. The 2001RS back panel

Don't open the T-2 or T-4 Oxygen Sensor bag until step 20 of this procedure!!!

1. Mount analyzer at a convenient eye level.
2. Confirm sample pressure is less than the analyzer specification (20psig). If it is higher, use a suitable regulator which must have a stainless steel diaphragm.
3. Deal with any potential condensation or liquid contamination issues.
4. Connect the sample line to the sample inlet port with ¼" ss tubing.
5. Pressurize the sample line to line pressure (between 1psig and 20psig).
6. Leak check every fitting and weld from the analyzer inlet to the sample tap.
7. Connect vent line to outside or a suitable purge system.
8. If using a span gas, connect it to the span port on the back of the analyzer. See step 25 below.

9. Connect power, relay contacts, analog output and RS485 if desired. If using conduit, run the power and alarms in one conduit, and the analog output and RS485 in the other.
10. Turn on the analyzer with the switch on the power entry module on the back panel.
11. Adjust the sample flow to approximately 1 SCFH with the Flow control valve.
12. Allow the sample gas to purge the unit for a few minutes. Make sure the cell cap is in place.
13. If you are not using the advanced features, set up the alarms and the output range from the front panel of the analyzer.
14. Optional:
 - a. Connect the laptop, run the User Interface version III and verify all alarm, output and security settings.
 - b. Set the analyzer clock time, and click on "Clear Data Log".
 - c. Verify the output calibration.
 - i. Connect the analog output terminals to an appropriate measuring device – preferably the monitoring device you are going to be using with this analyzer.
 - ii. Arrange that you can readily see the reading given by this device.
 - iii. On the AMI User Interface, check the "Zero" check box under SETUP in the ANALYZER SETUP section.
 - iv. Observe the response of the monitoring device, and adjust the number in the Zero box until the monitoring device shows what it considers to be zero (which should correspond with 4mA).
 - v. Check the box marked "Full Scale" in the SETUP section, and adjust the number in the box next to it until the monitoring device shows full scale. This corresponds to 20mA.
 - vi. Check the "Mid Range" box and verify that the monitoring device shows mid scale.
 - vii. Uncheck any boxes (if you forget, the analyzer will revert to its ordinary operation in ten minutes anyway).
15. Test the entire system, including anything controlled by the alarms or analog output, using a cell simulator (this is an optional device provided by AMI).
16. If not using span gas, press and hold the SPAN button on the front of the analyzer for 5 seconds until the LED turns blue. This will stop the sample flow.
17. Unscrew the cell cap, and install the oxygen sensor. Assure the sensor's plastic handle is pointing outward from the sensor cavity.
18. Remove the shorting tab on the sensor.
19. Optional: in the User Interface (version III) press the "NEW SENSOR" button, and record the sensor serial number.

20. If not using span gas, Stabilize for 45 seconds ONLY, adjust span to 20.9%. If it already shows 20.9%, press the UP arrow for a moment anyway (to tell the unit to switch back to sample gas).
21. If using span gas for calibration, stabilize the sensor by allowing sample (or zero) gas to flow at about 1 SCFH.
22. Replace the Cell cap and tighten it down (hand tight).
23. (If you are finished with setting it up) remove the USB connection cable.
24. Purge with sample gas for half an hour, or until the oxygen reading has fallen to low ppm levels.
25. If desired, span with known calibration gas.
 - a) Connect a regulator (with Stainless Steel diaphragm ONLY) to span gas tank.
 - b) Bleed high pressure side of the regulator 7 times.
 - c) Bleed low pressure side of the regulator 7 times.
 - d) Shut off the regulator outlet valve and leak check all the tank fittings, gauges and packing glands with Snoop™ or equivalent liquid leak detector (not spray).
 - e) Flow calibration gas WHILE you are connecting the tubing to the span gas fitting. Allow the gas to purge through the fitting for about 20 seconds before you tighten it.
 - f) Tighten fitting on the span gas inlet.
 - g) Press the ALARM BYPASS button, and adjust the time displayed to a suitable value (typically 10 minutes).
 - h) Press and hold the SPAN button for 5 seconds until the LED turns blue.
 - i) Allow to stabilize for 2-5 minutes.
 - j) Verify that the analyzer reads within about 15% of the span gas value.
 - k) If so, adjust the analyzer span (see below) until it reads the span gas value.
 - l) Let it go back to normal operation (the “SPAN” flag goes out on the LCD display and the LED turns green), then press the UP arrow and note the number displayed (the “Calibration factor”).
 - m) Turn off the valve on the span gas tank (so it doesn't all leak out).

If the span gas reads worse than 15% wrong, something is wrong either with the gas, or with the plumbing (you have a leak) or some other error. See the troubleshooting section for some ideas about curing this.

Laptop set up procedure:

1. Install InterfaceIII on your laptop. Contact AMI sales if you need the installation program.
2. Run the InterfaceIII Program.
3. On the User Interface screen, at the top, click the “Port” button. Note the ports listed.
4. **Make sure the analyzer is powered up**, and connect the USB cable to it.
 - a. **If you connect the cable without power to the analyzer, the port won’t appear.**
5. On the User Interface screen, at the top, click the “Port” button again, and you should see an additional port. Select this port.
6. Let the program figure out how to talk to the analyzer, and watch it load up all the boxes with numbers or words.
7. If you want to name the analyzer, click on the “User ID:” box. A dialog box will come up, asking for a password. Use “AMI” (in capitals) as the password, and then write in up to 12 characters as a name for the analyzer.
8. Set up the output range, that is the range used by the analog output and the alarms to scale the output for your monitoring device.
9. Make sure the security settings are the way you want them.
10. Go through the analog output calibration procedure if desired.
11. Set up the alarms to work as you desire – see the alarm section below for details.
12. If you are installing the sensor, click on the New Sensor button and write in the serial number.
13. Check the analyzer date and time is correct (we set it up for Pacific Standard time, which may not be correct for you). You can send the computer time to the analyzer by clicking the Set Analyzer Time button.
14. Clear the stored data by clicking the “Clear Data” button in the DATALOG section on the right.

Detailed Analyzer Description

Front Panel

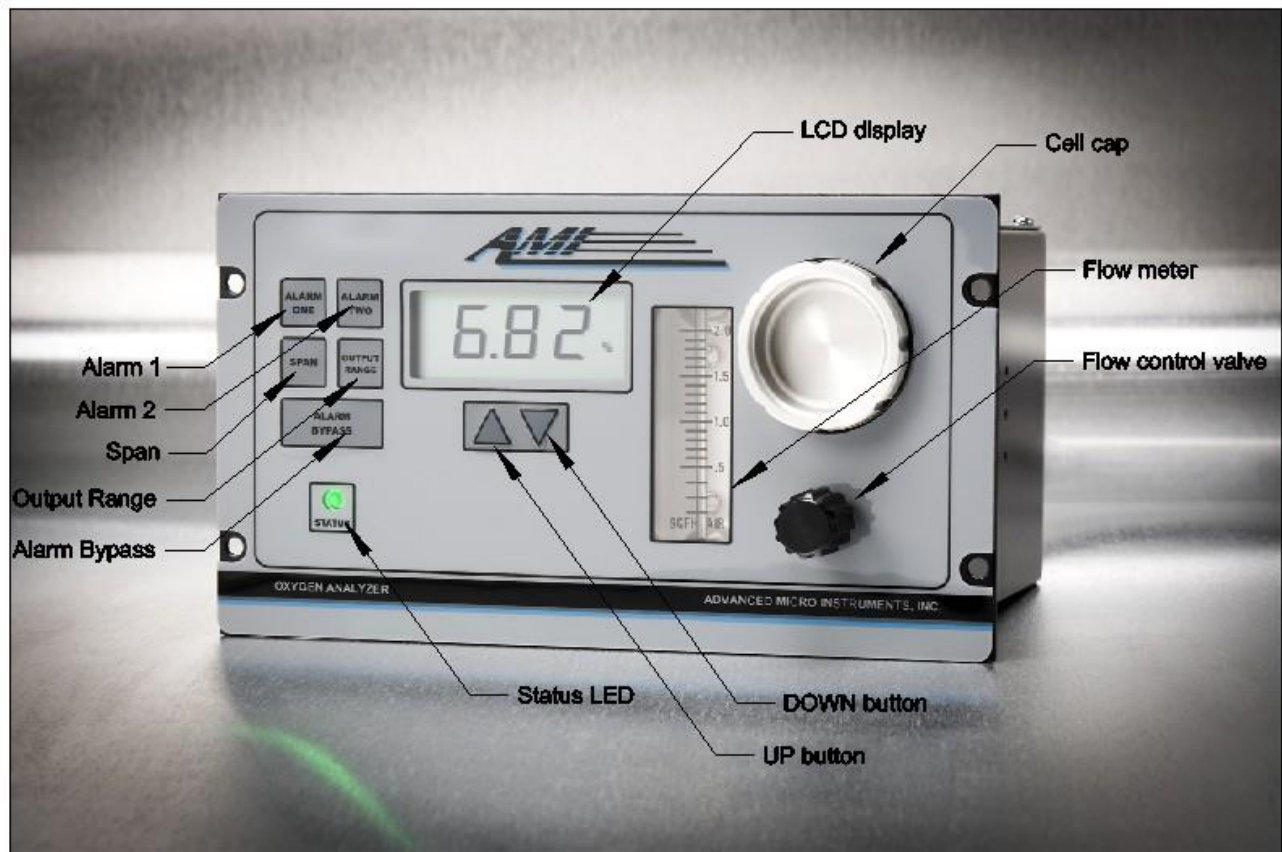

Figure 3. The 2001RS front panel

The analyzer electronic controls are on the left of the front panel, and the gas flow control and flow indication are on the right, along with the “Cell Cap” that covers the oxygen sensor. The oxygen reading is displayed on the LCD screen.

Gas flows in from the “Sample inlet” (or the “Span inlet”) on the back panel, up to and around the sensor beneath the cell cap, through the Flow Control Valve and then through the flow meter and then to the exhaust fitting on the back panel. Solenoid valves inside the analyzer select between the sample and span gases, and also seal off the sensor should power be removed. This prevents air from upsetting the sensor and

potentially destroying it when the power is off. Do not connect a positive pressure source directly to this analyzer – doing so will pressurize the sensor, causing inaccuracies and potential destruction of the sensor.

The analyzer does five main things with the oxygen reading. It **calibrates** it, using the “Span” function.

It **displays** it on the LCD screen. It reports the reading on its “**Analog output**”, a 4-20mA current loop. It **alarms** – i.e. fires two relays - in response to whether the reading is greater than or less than either of the two “Alarm set points”. The alarm can be bypassed by pressing the “**Alarm Bypass**” button. It reports the reading as requested on its **digital** outputs, either via USB into a PC or via ModBus into a control system.

The front panel controls can be used to affect most of these functions, as long as the security setting (in the AMI User Interface) is set so as to allow it.

Calibrate (“Span”) the analyzer:

It is important to calibrate the analyzer so that the reading corresponds to the actual oxygen content of the gas. This kind of analyzer inherently has zero output in the absence of oxygen, so it is only necessary to “span” the analyzer by making its reading on a high oxygen level gas correspond with the actual oxygen content of that gas. Air can be used for this, since air is held by natural forces to an oxygen content of 20.9%, but exposing the sensor to air has a number of undesirable effects and so often people use a “span gas” as the calibration standard. The 2001RS has built-in solenoid valves that allow such a span gas to be drawn into the analyzer and turns off the sample gas. You can make this happen by pressing and holding the “SPAN” button for five seconds. The solenoids will fire, and the LED on the front panel will turn blue. Allow the reading to stabilize, and then use the up or down arrow keys to scroll the reading to the value given on the span gas tank. Then simply leave the buttons alone and in a couple of seconds the solenoid valves will switch back and the analyzer will remember the new calibration factor that you implicitly generated with the up and down buttons.

There are some considerations however that you need to be aware of. See the section below called “Spanning the Analyzer” for details.

LCD display:

The oxygen reading is shown on the LCD screen, together with either the “ppm” or the “%” flag. Note that 1.00% is the same as 10,000ppm, or 0.1% the same as 1000ppm. The analyzer automatically scales its reading so that the display shows the correct value.

Analog output:

The analyzer has an isolated 4-20mA self-powered current loop output. It is capable of driving a 600 Ohm load and will saturate at more than 125% of the nominal full scale

range. “Isolated” means that the circuit has no ground connection, so that you cannot generate a ground loop inadvertently. However the overall connection must be grounded at one end or the other, if the monitoring device is also isolated. 4mA flowing through the loop means that the reading is zero, while 20mA means that the reading is full scale. But what does full scale mean? This is what we call the “Output range”, the range over which the 4-20mA output is scaled. You can select from many possible output ranges by pressing the “Output Range” button, at which the LCD will show the full scale of the currently chosen output range. You can change this by pressing the up or down arrow buttons until the range says what you want. Only certain ranges are possible, generally in multiples of five and ten, such as for example 10ppm, 50ppm or 100ppm. Whatever you select, the analyzer will scale the 4-20mA output over that range of values. When the arrow key is released the analyzer will store the new set point and revert to showing the oxygen reading.

Using AMI software you can force the output to 4mA (zero output), 12mA (half scale) or 20mA (full scale), and calibrate these values so as to get the most accurate possible transfer of information to a recording or computing device. If you forget to reset them the unit will automatically return to its normal operation after ten minutes.

It is possible to force the output to be a voltage output by connecting a resistor of appropriate value (62.5 Ohms will give 0-1V) across the output terminals (or better, across the input terminals of the monitoring device) and adjusting the zero and full scale values accordingly.

Alarms:

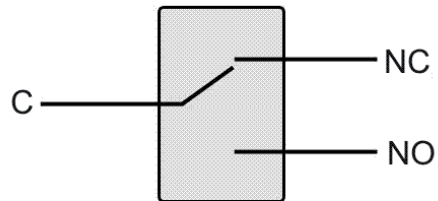

The alarm connections are single pole double throw relays, i.e. Form C contacts (technically a “common (C)” contact, and one that is connected to the common when the relay is powered (NO), and the other connected when the relay is unpowered (NC)) each of which can be set to change state when the oxygen level reaches a certain percentage of the output range. Typically they will be set so that the relay is powered when the unit is NOT in alarm, and to go into the unpowered, i.e. alarm state, when the oxygen level exceeds a certain value. This is what is called a high alarm (alarming when the reading goes high), in the “Failsafe” mode, meaning that the relay indicates an alarm either when the reading is too high, or else when the power has failed. There are many logical possibilities for the relay operation but they are selected using the User Interface

program and so are not described here. If the unit does go into an alarm the front panel LED will change color to red.

You can change the alarm set points using the “Alarm one” and the “Alarm two” buttons. When pressed, the LCD will show the currently active set point, and this can be changed by pressing the up or down arrows. When the arrow key is released the analyzer will store the new set point and revert to showing the oxygen reading.

If you connect the Common contact to the power source, and the NC (“Normally closed”) contact to the load, when the relay is unpowered the load will be turned on. If the relay is powered the load will turn off. If the alarm is set as a high alarm, in “Failsafe” mode, that means that when the analyzer has no power the load will be turned on, and also when the analyzer sees high oxygen the load will be turned on.

The contacts can handle AC or DC voltages, and can carry up to 5A of current for a resistive load. Inductive loads such as solenoid valves should be “snubbed” – we suggest that you connect diodes or Zener diodes or “Transzorbs” directly across them to absorb the inductive spike. Do not connect the snubbing diodes across the relay terminals on the analyzer, since the resultant current loop will transmit a lot of RFI that could upset sensitive devices nearby.

Digital outputs:

The analyzer has both a USB connection and an RS485 connection on its back panel. The former can be used with the AMI User Interface program to make use of all the advanced features possessed by the analyzer, while the latter can be used to allow a control system to interact with the analyzer over ModBus. ModBus is an industry – standard communication protocol often used by such systems. AMI can supply a manual that gives details on how to use this.

Alarm Bypass:

If the unit goes into an alarm the alarm can be temporarily silenced or disabled by pressing the “Alarm Bypass” button. If the analyzer is not in alarm, pressing the button will cause the display to show the alarm bypass time in minutes. If the analyzer was indicating an alarm, pressing the button will cause it to be turned off and held off for the period of the alarm bypass time. During this time the LED will glow yellow, rather than red. If the alarms are programmed to latch, pressing this button will also unlatch them (and stop them from alarming again for the hold off period).

LED:

The front panel LED will change from green to red if the unit goes into alarm. If the ALARM BYPASS button is then pressed, the LED will turn yellow and the alarm relays

will go into their non-alarm state. If the SPAN button is held for five seconds, the span solenoid will activate and the LED will change color to blue, and flash on and off, indicating that the unit is in span mode. If it goes into alarm while in span mode, the LED will flash between red and magenta (a blue/red combination). If the unit is put into leak-check mode (via the User Interface) the LED will flash yellow. It can only come out of leak check mode either by waiting for 8 hours or by the appropriate command from the user interface.

Up button - Span Factor:

The analyzer features a “Span Factor” display to help you determine the state of the sensor. As the sensor ages, its output decreases gradually, and therefore the span factor has to be turned up during calibration to compensate.

Press and release the UP button while the unit is showing its reading to view the span factor. The factor corresponds to the setting of a traditional ten turn span pot with a turns counter dial on it.

The setting should be between 300 and 600 for a new sensor. When you calibrate the analyzer, check this value before and after the calibration. You should see that the value goes up slowly over the life of the sensor. When the value has gotten up to about 850, the sensor has reached the end of its life and should be replaced. Also, if the value suddenly jumps, it indicates that the sensor is getting close to the end of its life.

Down button – Temperature reading:

If you press the DOWN arrow button the display will show the temperature of the cell block in degrees Fahrenheit. The value is limited to 25°F at the lowest, and about 120°F at the highest. Values outside this range will damage the sensor! If the unit is equipped with a heater (for measuring oxygen in pure CO₂), the temperature shown will probably be higher than ambient.

Back Panel



Figure 4. The 2001RSP back panel

The back panel contains all the gas and electrical connections for the analyzer.

AC power

The analyzer requires AC power between 90 and 240VAC, 50/60Hz, even though the fuse panel shows 110V. It uses a standard IEC connector, and draws very little power so that a standard AC power cord is perfectly adequate.

Serial Communications:

The 2001RS provides two serial connections – a USB port that can talk to a PC running the AMI User Interface software, and an RS485 connection that supports the standard ModBus protocol. The unit detects the presence of a USB connection, and disables the RS485 connection if one is detected. This allows you to leave it connected to the RS485 loop while you configure the analyzer with the AMI program.

The USB connection supports the proprietary AMI protocol, and AMI provides a program on a CD that interfaces with the analyzer. Alternatively it is possible for someone

familiar with communications on a PC to directly use the protocol. See the AMI communications manual for details.

The RS485 port supports ModBus RTU at 9600 baud.

For details see the communications manuals provided upon request.

Sample Handling:

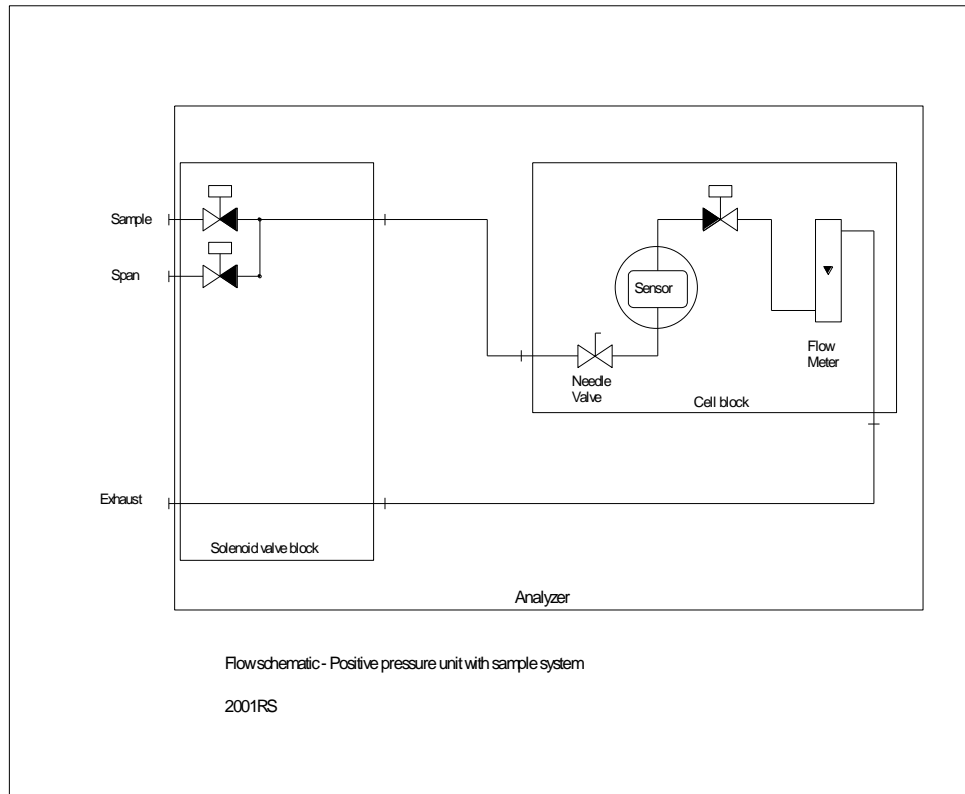

Figure 5 Flow Schematic of the 2001RS.

This analyzer expects to see a positive inlet pressure between 1-20psig. It contains an integral needle valve and flowmeter for controlling and observing the sample flow. It also contains solenoid valves that seal off the sensor when power fails, and also that can select between the sample and a span calibration gas.

The span gas should be at the same pressure as the sample (so the needle valve doesn't have to be adjusted when you select one or the other). Make sure that you turn off the span gas cylinder valve when you are not using it – otherwise you may lose all the span gas if you have a tiny leak in the system somewhere.

The exhaust should be vented to atmosphere or to atmospheric pressure. The oxygen reading will be affected if the pressure the sensor sees is not atmospheric.

The front panel LED will change from green to red if the unit goes into alarm. If the ALARM BYPASS button is then pressed, the LED will turn yellow and the alarm relays

will go into their non-alarm state. If the SPAN button is held for five seconds, the span solenoid will activate and the LED will change color to blue, and flash on and off, indicating that the unit is in span mode. If it goes into alarm while in span mode, the LED will flash between red and magenta (a blue/red combination). If the unit is put into leak-check mode (via the User Interface) the LED will flash yellow. It can only come out of leak check mode either by waiting for 8 hours or by the appropriate command from the user interface.

Operation

General Information

Basic knowledge about oxygen measurement

Oxygen is a chemically active gas that is present in the atmosphere at 20.9% concentration. It is essential for animals including humans as it is the active part of air used in breathing. However since it is so active, small amounts of it can cause havoc in situations which are not supposed to have it. In natural gas, for example, small amounts of oxygen cause the other chemicals present in the gas to combine to form acids that destroy piping and chemical systems; in semiconductor manufacturing it changes expensive integrated circuits into sand, or at least stops them from working properly. In chemical operations it can prevent polymerization or otherwise degrade the performance of the process.

Gases obey the gas laws formulated in the end of the 18th century and still not well understood by many people. A gas consists of a very large number of independent molecules that fly around in otherwise empty space. Gases don't interact with each other (normally), so that you can treat the behavior of each gas as if no other gases were present. Thus you can consider that air consists of nitrogen at about 11 psia, and oxygen at about 3 psia, and various other gases at lower pressures. "psia" stands for Pounds per Square Inch Absolute, i.e. it is the pressure above zero, not the so-called gauge pressure. Since we are only worried about oxygen, mostly because nitrogen does not matter normally to the chemistry we are worried about, we can think of air as acting like pure oxygen at 3 psia pressure. In a pure gas stream, there is zero oxygen ideally, i.e. it is at zero pressure. This means that if there is a leak in the tubing, a pressure difference of 3psia exists forcing oxygen into the leak. The oxygen doesn't care about or see the other gas in the tube, it thinks of the tube as being a vacuum. People normally don't intuitively understand this, they think of the gas as being rather like a pipe full of oil in the sea, such that if there's a leak oil will come out into the sea but the oil will keep any water out of the pipe. However that's not the way it is with gases because the space between the molecules is very much larger for a gas than it is for a liquid, so one gas does not push another out of the way.

The bottom line is that oxygen from the air will force its way into a pure gas system regardless of the pressure in the system. It will do this through little holes, or through permeable materials such as all plastics or rubbers, to greater or lesser extent. Nitrogen will do this as well, but since nitrogen is comparatively inert normally its presence doesn't matter. Also it is much harder to measure, while oxygen is comparatively easy, hence oxygen is normally used to verify the integrity of the system.

As a consequence of this, the integrity of the oxygen analyzer sample system is critical. AMI analyzers are designed around a patented "Cell block" that integrates all of the sample handling elements into one solid chunk of metal, resulting in much fewer leak sources and therefore much greater reliability, as well as lower cost.

Analyzer operation

It is just as important that the analyzer's sample system – the set of components used to control the gas flow – is perfect as is the measurement methodology itself.

Sample tubing and components

Oxygen diffuses through plastics, to a greater or lesser extent. Standard blue poly tubing will diffuse about 1ppm per foot into 1SCFH at 70°F. Silicone tubing is very much worse. In general, use stainless steel tubing, or at least copper tubing, not plastic. Use high quality compression fittings such as "Swagelock™" or "Gyrolock™" and high quality stainless steel filters, valves or regulators if necessary. Make sure that they are assembled correctly and perform a thorough leak test on the sample system before use.

Leaks

If you suspect a leak due to high oxygen readings, change the flow rate and see how long it takes for the oxygen reading to change. A higher flow rate will dilute the effects of a leak so that the reading will drop as you increase the flow (this is a very good way of making sure that you do not in fact have a leak, by the way). Turn the flow up from 1 SCFH to 2 SCFH using the front panel valve and see how long it is before the reading changes. If it does so immediately, the leak is close to the analyzer. If it takes longer, the leak is further away.

Exhaust

The exhaust may be returned to the source if practical (so as not to lose gas). Otherwise, if the sample gas is innocuous, such as pure nitrogen, it can be vented into the room with no ill effects, if the room itself is ventilated. Otherwise it should be vented outdoors or brought into a scavenging system.

Calibrating the analyzer

The oxygen sensor gradually gets used up over its life, and as it does so its sensitivity slowly drops until it is at the end of its life, when the sensitivity drops much faster. Therefore you have to calibrate the sensor every so often to make sure that your readings are correct.

There are two ways of doing this. You can use a span gas, a mixed gas containing a certain level of oxygen in a background gas that ideally matches your sample, or you can use air. The advantage of using air is that its value really is 20.9% and it doesn't change; the disadvantage is that it means that the sensor is exposed to air and so it will take a while for the reading to come down again afterwards. Typically, at room temperature, and AMI analyzer will take about twenty minutes or less to come down to below 10ppm after a one minute exposure to air.

The advantage of using a span gas is that you can calibrate it to a value close to the range of interest. Although ideally the background gas ought to be the same as the sample gas, it is often impractical to get such gas mixtures particularly if the background gas contains a flammable gas. Fortunately nitrogen is normally adequate as the background, and often 80ppm oxygen in nitrogen works well as a low level span gas. The main exception is when helium is the main ingredient of the background. Sensors do not like rapidly swapping between helium and other gases and in this case it is strongly recommended that you do use a helium/oxygen mixture as the span gas.

The sensor recovers from this level of oxygen immediately so there is no down time before the analyzer is working properly again.

Be aware that it is quite possible for span gases to be made incorrectly or contaminated with air by incorrect handling. If there is some question about a span gas try doing an air calibration and then simply measuring the span gas. If the analyzer disagrees with the label on the bottle by more than a few percent there is a very good chance that the bottle is contaminated.

Calibrating with a span gas

First put a suitable regulator on the span gas tank, and "bleed" it as described below. This step is essential, since otherwise the air in the regulator will contaminate the gas in the tank. Connect the regulator to the back of the analyzer with a stainless steel line, and leak check the connection with "Snoop™" or similar leak detection fluid (using a pressure of no more than 20psig). Then loosen the fitting on the back of the analyzer and flow the span gas for a couple of minutes prior to starting the span process. This prevents a slug of air from giving you excessively high readings when you start spanning the analyzer.

Before performing a low level span, make sure the analyzer is seeing a low oxygen level gas – you want the analyzer to go UP to the span gas, not down to it, particularly not from air. Otherwise it will take a very long time to get a good calibration.

When all is assembled and the line has been purged for a couple of minutes, press and hold the “SPAN” button on the analyzer for five seconds or until the LED turns blue. Span gas is now flowing into the analyzer, and you should see the reading move to the span gas value. Assuming it stabilizes somewhere reasonably close, press the UP or DOWN button until the reading on the LCD shows what the span gas bottle says the value should be. Let go of the buttons, and after a second or two the analyzer will shut off the span gas and go back to the sample gas, and the LED will turn green.

Calibrating with air

The simplest way is to connect a compressed air line set at no more than 20psig to the span inlet. Alternatively if you do not have compressed air available, leave it disconnected and when you place the unit into the span mode, unscrew the cell cap and blow air underneath the sensor. Make sure you don't take more than a minute to do an air calibration. The reading may not stabilize exactly at 20.9%, but don't worry about that – any slight error will be inconsequential at the operating levels.

Let the analyzer come down to a low reading on the sample gas.

Alarm Bypass

Press the alarm bypass button prior to calibration if you have the alarms attached to anything, so as to stop them from going off when the analyzer sees the high oxygen level in the calibration gas. You can adjust the hold off time when you press that button – it shows what the hold of time is, and you can change it with the UP or DOWN buttons as desired. The analog output will also be held constant during this time.

Span problems

Sometimes you will run into problems. If the sensor is old, it may not be able to come up to the span gas level. If so, you need a new sensor. Sometimes a sensor will calibrate on span gas but will fail on air. This also indicates an old sensor. You can see the sensor state by pressing the UP button when the sensor is showing the oxygen level – it displays the “Span factor”, a number between about 450 and 1000. As the sensor gets old each calibration will increase this number and when it gets up to about 850 it is time to replace the sensor.

Sometimes the sensor won't calibrate on span gas properly, but since it is a new sensor you figure something must be wrong. If something like this is happening, perform an air calibration and then allow the sensor to come back down to a low reading on the sample. Then perform a span gas calibration only don't adjust the span factor with the UP or

DOWN buttons, and see what the analyzer says the gas contains. If the gas value isn't what you think it should be, it is the gas that is wrong, not the analyzer, because that air calibration is in fact very valid. You will have to trouble shoot whatever has happened with your gas.

Using the analyzer

Output Range

The analyzer displays the oxygen level in appropriate units on the LCD, automatically adjusting its sensitivity as required. Meanwhile the analog output and the alarms (as well as the data log) are set on a single (user selectable) "Output" range.

For example, you can set the analog output to correspond to 0-100ppm, and the alarms to be 40ppm and 50ppm (i.e. 40% and 50% of range), activating above set point. If the oxygen level actually is 25ppm, the display will show 25.0ppm, and the output signal will be at 25% of full scale. If the oxygen level becomes 200ppm, the display will show 200ppm, but the 4-20mA output will be saturated, and the alarms will both be activated.

If you now manually change the output range to 0-1000ppm, the reading will stay at 200ppm, the 4-20mA output will go to 20% of scale, and the alarms will de-activate, since they now correspond to 400ppm and 500ppm, i.e. still 40% and 50% of range. However if the alarms were set to latch, you would have to acknowledge them by pressing the ALARM BYPASS button before they would de-activate.

Output ranges	0-10ppm, 0-50ppm, 0-100ppm, 0-500ppm, 0-1000ppm, 0-5000ppm, 0-1%, 0-5%, 0-25%.
---------------	--

Security:

Through the user interface, three levels of security can be set. These are: No security (all front panel controls are active), Span (only the span control and the ALARM BYPASS button are allowed to operate), and Full security (only the ALARM BYPASS button performs a function; other buttons will show settings but won't allow them to be changed). If the front panel controls don't seem to work, use the AMI User Interface to change the security settings.

Advanced Features

The analyzer has many advanced features that are only accessible through the AMI User Interface. For details see the User Interface manual. The features include a data log, a calibration log, power failure log, and many other detailed bits of data. Most of these features are also available over the ModBus link.

Maintenance and troubleshooting

Maintenance:

The model 2001RS is virtually maintenance free other than for periodic calibration and occasional sensor replacement.

Periodic Calibration:

The analyzer should be calibrated about once every month to obtain the best accuracy. The sensor typically declines in sensitivity by about 1% per month, so a monthly calibration is usually satisfactory. Use in a particularly aggressive environment may degrade the sensor faster: in this case calibrate more often.

Sensor Replacement:

This should be done based on the Span Factor feature, rather than as a response to a dead sensor. See the chart below for recommended sensor replacement.

Sensor	Part number	Description	Expected life
T2	4SEN09-1	Trace oxygen – CO2 background	9 months to 2 years
T4	4SEN18	Trace oxygen – CO2 background, up to 500ppm H2S	9 months to 2 years

Table 1. AMI sensor types

CAUTION: The sensor contains an acid liquid. If there is any sign of a liquid in the cell compartment, do not allow it to come into contact with your skin. If it does, immediately flush the affected area with water for a period of at least 15 minutes. Refer to the Material Safety Data Sheet provided.

Dispose of leaking or used sensors in accordance with local regulations. Sensors usually contain lead which is toxic, and should generally not be thrown into ordinary trash. Refer to the MSDS to learn about potential hazards and corrective actions in case of any accident.



Figure 6. Inserting sensor in cell block

Sensor replacement procedure:

The sensor is provided in a special sealed bag. Do not open this until you are ready to install the sensor.

1. Make sure you do not have any span gas flowing.
2. Turn off the sample gas flow by pressing and holding the SPAN button on the front panel of the analyzer.
3. Unscrew the cell cap.
4. Remove the old sensor.
5. Open the bag containing the new sensor.
6. Push the new sensor into the block using its handle as shown above.
7. Holding the sensor in place, pull out the stainless steel tag.
8. Allow the reading to stabilize for 45 seconds, then span the reading to 20.9%
9. If you did not have to adjust the span to change the oxygen reading in step 8, press the UP button momentarily (this will let the analyzer turn the sample gas back on).
10. Replace the cell cap.

11. Screw it down tightly but only hand-tight.
12. Dispose of the old sensor in an environmentally appropriate way. It is similar to a lead-acid battery in terms of environmental hazard.

Bleeding a regulator

A newly installed regulator on a bottle of span gas is of course filled with air, at 210,000 ppm of Oxygen. Until this air is removed, the apparent oxygen concentration in the span gas will be much higher than it should be. While simply flowing the span gas will eventually accomplish this, it is much quicker and more reliable to “Bleed” the regulator first.

1. Install the regulator on the span gas bottle, but do not open the bottle valve yet.
2. Close the regulator exit valve.
3. Close the regulator to what would be no pressure on the outlet.
4. Briefly open the bottle valve, and close it again.
5. Loosen the nut connecting the regulator to the bottle and allow the pressure to bleed off, and then tighten it again.
6. Open the regulator to half its maximum pressure.
7. Repeat steps 4 and 5.
8. Open the regulator to its maximum exhaust pressure.
9. Repeat steps 4 and 5.
10. Set the regulator to its correct output pressure (typically 10 psig).

Troubleshooting

All oxygen applications

Analyzer does not power up.

1. Check that the power is connected correctly, and the switch on the power entry module is on.
2. Check that the fuses in the power entry module are not blown. If they are, it indicates that something has gone seriously wrong. Only replace them with 1A fast blow fuses – if these blow, return the unit to AMI for repair.

Analyzer reads too low

1. Sensor is not calibrated. Flow span gas through it and span the analyzer until the analyzer reads appropriately.
2. Span gas was not bypassed so the analyzer was spanned incorrectly. Bypass the span gas as suggested earlier in this manual.
3. If you still cannot adjust the span enough, replace the sensor.
4. If the new sensor still reads too low, check its calibration with air and read the span gas - the span gas may be incorrect.
5. If the sensor seems to die quickly, it may be getting poisoned by acid or sulfur bearing gases such as H₂S. Use the H₂S resistant T-4 sensor.
6. Verify that the cell block connectors are in fact making contact with the cell. Clean them gently with a Q tip, and bend them slightly straighter so that they make a good contact. Once this is done the cell should have some resistance to being removed from the block.

Analyzer reads too high

1. Verify that there is no flow restriction in the vent line of the analyzer.
2. Increase the flow rate through analyzer - if the reading goes down it indicates a leak in the incoming sample line or the cell block. Use “Snoop™” or equivalent to check all the fittings back to the gas source.
3. Leak test all external fittings with “Snoop™” soap solution or equivalent.
4. Verify that the gas flow rate is correct. (0.1 to 2 SCFH)
5. Oxygen diffusion can be a serious problem. Verify that no plastic tubing or other plastic components are used in a trace gas system, including diaphragms of pressure regulators, packing of valves etc. For percent applications, similar problems may be

experienced with silicone tubing. Use Teflon™ or Tygon™ or similar high quality tubing.

6. Verify the analyzer calibration using air as the span gas.
7. Flow zero gas through the analyzer until the reading stabilizes at as low a level as it gets to. Note the reading (it should be in the low ppm's). Turn off the analyzer power for an hour or so, and turn off the zero gas at the tank. Then turn the analyzer back on, and see what the reading shows. It should be somewhere between about 50ppm and 200ppm. If it is much higher, the analyzer has an internal leak and will have to be returned to the factory for evaluation and repair.

NOTE: Almost always, high oxygen readings are due to leaks. Oxygen in the air is under a partial pressure of about 3 psia at sea level, and thus will force its way into minute leaks, no matter what the internal pressure of any other gas may be. 3000 psig nitrogen or other gas lines look like a vacuum to oxygen! This always surprises people who have not experienced it.

Analyzer reads zero

1. Verify that the sensor is in the correct position, not upside down. If it is upside down, verify that the membrane has not been punctured - i.e. there is no sign of electrolyte on the surface, and if not, put it back the right way up. If you have left it this way for a while, it may take several hours to recover to a low reading.
2. Verify that the cell block contacts are touching the sensor. Pull the sensor tab, and the contact should hold the sensor with a gentle force. If not, the contacts may be bent. If they have been bent too much, remove the sensor and gently bend them back so that they can again make contact.
3. Make sure that the gold plated contact wires are clean. If not, gently clean them with a Q tip or an eraser. Do not use an abrasive cleaner, as it will remove the gold plating.
4. Check the output of the sensor with a DVM configured to measure current. Connect its leads to the two gold rings on the back of the sensor - the center is ground. The output should be around 150 to 750 micro Amps in air. This will take a few minutes to stabilize as the sensor consumes oxygen dissolved in its electrolyte. Replace the sensor if it does not read this amount. See sensor replacement instructions under Maintenance.

No voltage or current output to recording device

1. Verify that the output wires are properly stripped and connected.
2. Verify the connections on the output terminal block.

3. Verify that the output connections are not shorted all the way back to the recording device. Disconnect the wires from the analyzer and use an ohmmeter to check for shorts or opens.

No output alarm indication

1. Verify the alarm set points are correct - press the appropriate switch on the front panel, and check the displayed reading on the LCD for correct setting.
2. Verify that the connections on the terminal block are properly stripped and correct.
3. Verify that the alarms are configured correctly, using a PC or similar communication device.
4. Verify the alarm delay time with the PC.
5. Verify that the output connections are not shorted all the way back to the recording device. Disconnect the wires from the analyzer and use an ohmmeter to check for shorts or opens.

Incorrect readings

1. Verify that there are no leaks in the system.
2. Verify that the span gas bottle is correctly marked by comparing its reading when the analyzer has been spanned on air to what it actually says.
3. If spanning on air, verify that the air source is free of water vapor (humid air will contain about 3% less oxygen than expected, depending on temperature), and that bottle air does actually contain 20.9% oxygen. Manufactured air often does not!

Analyzer refuses to accept front panel settings

1. Using the USB port and the AMI User Interface, verify that the security is set the way you want it.

Still no correct operation

1. Call AMI at 714 848 5533, and ask for Technical assistance.
2. Or contact us by email at sales@amio2.com.

Specifications and Disclaimer

Specifications:

- 2001R Series Standard ranges:
 - 0 – 10 ppm, 0 – 50ppm, 0 –100 ppm, 0 – 500 ppm, 0 – 1000ppm, 0 – 5000 ppm, 0 – 1%, 0 – 5%, 0 – 10%, 0 –25%
- Sensitivity: 0.5% of full scale
- Repeatability: +/- 1% of full scale at constant temperature
- Operating temperature: 41°F to 113°F.
- Maximum inlet pressure: 20psig
- Humidity: < 85%, non-condensing
- Operational conditions: Pollution degree 2, Installation category I I.
- Drift: +/- 1% of full scale in 4 weeks at constant temperature
- Expected cell life: 9 months to 2 years.
- Response times (dependent on sensor):
- 90% of full scale in less than:
 - 0 – 10 ppm 25 sec
 - 0 – 100 ppm 10 sec
 - 0 – 1000 ppm 10 sec
- Outputs: 4-20mA isolated.
- Alarm contacts: 230/117VAC @ 5A, or 28VDC @ 5A, resistive
- Datalogger: Logs data for 15 days @ 1 minute intervals; 30 days @ 2 minute intervals, etc. Represents the output range selected: 0-10ppm, 0-50ppm, 0-100ppm, 0-500ppm, 0-1000ppm, 0-.500%, 0-1%, 0-5%, 0-10% and 25%. Overrange capability up to ten times the range selected.
- Power requirements: 90-240VAC <10W.
- Absolute Maximum Power voltage 264VAC 60Hz.
- ¼" Stainless Steel compression fittings for sample, span gas and exhaust.
- Overall dimensions: 9" w x 5" h x 7" d
- Mounting hole dimensions: 7.92" w x 4.81" h
- Weight 10 lbs.

To be installed only in installation (overvoltage) category I or II.

Disclaimer

Although every effort has been made to assure that the AMI analyzers meet all their performance specifications, AMI takes no responsibility for any losses incurred by reason of the failure of its analyzers or associated components. AMI's obligation is expressly limited to the analyzer itself.

The AMI analyzer is not designed as a primary safety device, that is to say it is not to be used as the primary means of assuring personnel safety. In particular it is not designed to act as a medical instrument, monitoring breathing air for correct oxygen concentration, and should not be used as such when it is the only safety device on the gas system.