

# SCHS-3 Sample Conditioning Heated System



CONDITION



REGULATE



SAMPLE



The SCHS-3 is a compact multi-stage heated pressure and temperature conditioning system designed specifically for use in gas analytical systems.

## FEATURES

- Pitot style probe design
- Liquid coalescer and filtration barrier
- Low internal gas volume
- Multi-stage heating design and regulation
- Sample gas outlet pressure and temperature indicator
- Liquid shut-off valve (Optional)

## BENEFITS

- Self-generated flow reduces stagnant inlet gas to improve real time sampling
- Self-generated flow maintains inlet gas temperature, reducing phase change
- Eliminates saturation of liquid barrier
- Reduces flashing of condensate
- Prevents supply pressure effect to maintain consistent outlet pressure
- Reduces cooling effect from pressure drop
- Easy installation with compact footprint
- Emergency shut-off prior to analyzer (Optional)



## SPECIFICATIONS

SCHS-3 Conditioning System

### SCHS-3

Application	Lean Gas, Rich Gas, High Pressure Gas, Wet Gas
Materials of Construction	316/316L Stainless Steel and 304 Stainless Steel, Anodized Aluminum
Seal Material	FKM
Operating Temperature	Ambient -50 °F to 120 °F (-45 °C to 48 °C) Process 32 °F to 300 °F (0 °C to 148 °C)
Maximum Inlet Pressure	3600 psig (248.21 barg)
Power Requirements	80 W @ AC 110/220 V 25 W @ DC 24 V
Sample Outlet	1/8" Tubing
Probe Length	Standard for 2" and 3" Pipe Standard for 4" and 6" Pipe Standard for 8", 10", and 12" Pipe Standard for 14", 16", and 18" Pipe
Pipeline Connection	1/2" MNPT 3/4" MNPT 1" MNPT 2" - Class 300 RF 2" - Class 600 RF
Regulator Output Range	0-50 psig (0-3.44 barg) 0-100 psig (0-6.89 barg) 0-200 psig (0-13.78 barg)
Electrical Connection	1/2" FNPT
Flow Coefficient	(Cv) 0.001
Electrical Components Approval Available	CSA Class I, Div. 1, Groups B, C, and D, T3 / ATEX II 2 G Ex d IIC T3, IP68, NEMA 4X

## STANDARD CODE TREE OPTIONS

SCHS-3 Sample Conditioning Heated System

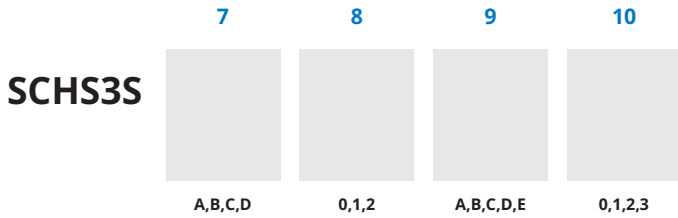

### 7 Inlet Pressure

**A:** 300–500 psig (20.68–34.47 barg)  
**B:** 500–1000 psig (34.47–68.94 barg)  
**C:** 1000–2000 psig (68.94–137.89 barg)  
**D:** 2000–3600 psig (137.89–248.21 barg)

### 8 Regulator Output Range

**0:** 0–50 psig (0–3.44 barg)  
**1:** 0–100 psig (0–6.89 barg)  
**2:** 0–200 psig (0–13.78 barg)

### 9 Pipeline Connection

**A:** ½" MNPT  
**B:** ¾" MNPT  
**C:** 1" MNPT  
**D:** 2" – Class 300 RF  
**E:** 2" – Class 600 RF

### 10 Probe Length

**0:** Standard for 2" and 3" Pipe  
**1:** Standard for 4" and 6" Pipe  
**2:** Standard for 8", 10", and 12" Pipe  
**3:** Standard for 14", 16", and 18" Pipe

## PRODUCT DIMENSIONS

SCHS-3 Sample Conditioning Heated System

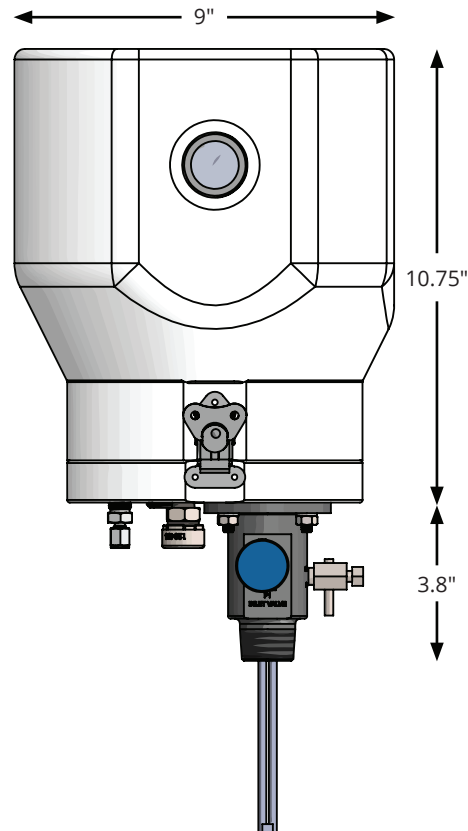

Weight: 20 lb

Weight and/or dimensions are approximate.  
Specifications subject to change without notice.



13839 WEST BELLFORT STREET SUGAR LAND, TEXAS 77498 | 281.491.2331 | sales@welker.com | [WELKER.COM](http://WELKER.COM)  
©2023 Welker, Inc., All Rights Reserved. Welker®, W Welker®, W Logo, WelkerScope®, Welker Jet®, and OdorEyes® are registered trademarks owned by Welker, Inc.