

VÁLVULAS DE COMPUERTA / GATE VALVES

VALVULA DE COMPUERTA ACERO CARBONO. PN16. HUSILLO ASCENDENTE. BRIDAS PN16
GATE VALVE C. STEEL. NP16. RISING STEM. FLANGED ENDS DIN NP-16



VALVESEAL
valves & sealing solutions

TF-MGV-CS-F



UTILIZACIÓN / APPLICATION :

Distribución de agua, gas oil, vapor, petroquímica, petróleo, gas
 Water distribution, nafta, steam, petrochemical, petroleum, gas.

CARACTERÍSTICAS GENERALES / GENERAL CHARACTERISTICS :

Medidas / Size DN50 - DN400.
 Husillo ascendente / Rising stem.
 Volante fijo no ascendente / Fixed non rising handwheel.
 Bonete atornillado / Bolted bonnet.
 Cierre metal-metal con asiento estelitado / Stellite Metal-metal seat TRIM 8.
 Cuña flexible de una pieza / Flexible one piece wedge.
 Pintura Gris / Painting Grey color RAL 7001 60µm

NORMATIVAS / STANDARDS :

Fabricación / Manufacture according to ISO 9001 : 2015 and ISO 14001: 2015.
 Directiva CE / Directive 2014/68/EU: CE Nº 0036 Risk Category III module H.
 Pruebas de presión / Pressure Tests according to EN 122661-1 Rate B.
 Longitud / Face to face according to EN 558-1 Series 15.
 Bridas R.F. / R.F. flanges according to EN 1092-1 PN16.
 Diseño / Design according to EN 1984 & EN 12516-1.
 ATEX / ATEX Group II Category 2G/2D zone 1&21 zone 2&22 according to directive 2014/34/EU.
 Marcaje ATEX opcional / Optional ATEX marking.

CONDICIONES DE SERVICIO / WORKING CONDITIONS :

Máxima presión de trabajo / Maximum Working Pressure : 16 bar.
 Temperatura máxima de trabajo / Maximum Working Temperature : -29 °C / +425 °C.



MATERIALES / CONSTRUCTION :

No.	Pieza Part	Material Material
1	Cuerpo Body	ASTM A216 WCB
2	Asiento Seat	ASTM A105 + Stellite Gr.6
3	Cuña Wedge	ASTM A216 WCB +13Cr
4	Eje Stem	ASTM A182 F6a
5	Perno Stud bolt	ASTM A193 Gr. B7
6	Tuerca Nut	ASTM A194 Gr. 2H
7	Junta tapa Bonnet gasket	AISI-304 + Graphite
8	Tapa Bonnet	ASTM A216 WCB
9	Asiento trasero Back seat busing	Coating 13Cr
10	Empaquetadura Packing	Grafito Graphite
11	Puente Yoke	ASTM A216 WCB
12	Tuerca Eje Stem Nut	Bronce + aluminio Aluminium + bronze
13	Anillo Ring	E51100
14	Volante Handwheel	Hierro fundido Cast iron
15	Prensa Packing Gland	ASTM A276-420
16	Brida prensa Gland flange	ASTM A216 WCB

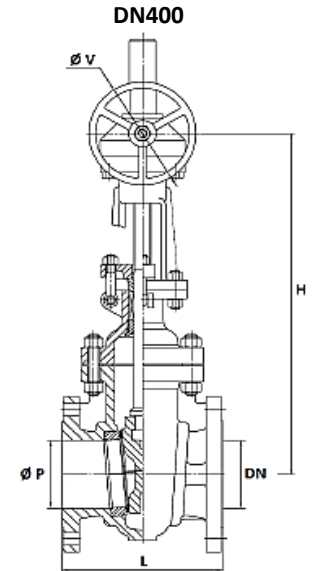
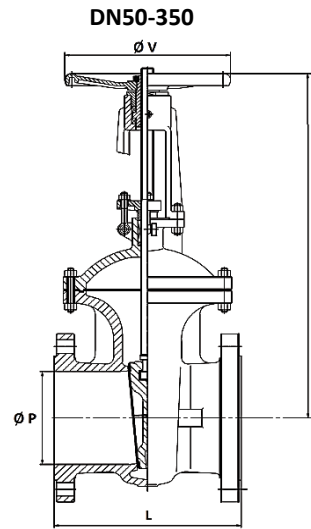
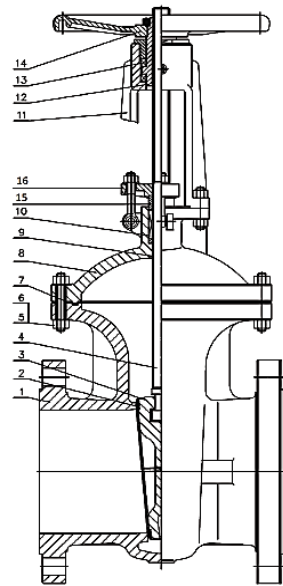

DIMENSIONES / DIMENSIONS :

DN ND	ØP	L	H (closed)	H (opened)	ØV	Par Nm Torque Nm	Kvs	Nº Vueltas No of cycles	Peso Weight
50	50	250	330	390	240	35	265	15	20,00
65	63	270	370	460	240	75	423	19	28,00
80	76	280	430	515	280	90	614	19	35,00
100	100	300	505	590	300	106	1124	22	50,00
125	125	325	545	675	300	137	1807	26	61,00
150	150	350	610	780	350	160	2690	33	81,50
200	200	400	750	960	400	255	4940	42	125,00
250	250	450	900	1190	450	375	7720	46	226,00
300	300	500	1040	1352	500	510	11540	52	290,00
350	336	550	1215	1570	600	710	14070	59	425,00
400 *	387	600	1335	1335	460	1018	18650	50	434,00

* 16" Reductor / Gear Box

Las especificaciones del producto están sujetas a modificaciones sin previo aviso. The specifications of the presented products are open to modifications without previous advice.