

VÁLVULAS DE BOLA / BALL VALVES

VÁLVULA DE BOLA ALTAS PRESTACIONES. INOX PN20. BRIDAS ANSI 150 Lbs RF 2 PIECES HIGH PERFORMANCE BALL VALVE S.STEEL NP20 FLANGED ENDS ANSI 150# RF



VALVESEAL
valves & sealing solutions

TF-BVSS-F150-HP



CE



NACE MR01-75

UTILIZACIÓN / APPLICATION :

Aplicaciones en industrias químicas, petroquímicas, calefacción, agua e instalaciones hidráulicas.
Chemical and petrochemical industries. Hydraulic installations. Heating and water distribution.

CARACTERÍSTICAS GENERALES / GENERAL CHARACTERISTICS :

Paso total / Full Bore.
Eje anti-expulsión / Anti blow-out stem.
Montaje ISO 5211 / ISO 5211 Mounting pad.
Cuerpo de 2 piezas / Split body type.
Doble dispositivo antiestático / Double Anti Static device.
Palanca con dispositivo de bloqueo / Locking Device.

NORMATIVAS / STANDARDS :

Diseño / Design according to ASME B16.34.
Directiva CE / Directive 2014/68/EU: CE -PED.
Pruebas de presión / Pressure Tests according to API 598 Table 6.
Bridas RF / RF Flanged ends according to ASME B16.5 Class 150.
Diseño Anti-fuego / Fire Safe according to ISO 10497: 2004
Emisión de fugas / Fugitive Emissions according to EN 15848-1: 2006

CONDICIONES DE SERVICIO / WORKING CONDITIONS :

Máxima presión de trabajo / Maximum Working Pressure : 20 bar.
Temperatura máxima de trabajo / Maximum Working Temperature : - 50 °C / + 230 °C.
Vacío / Vacuum : 10² torr.
Vapor / Steam 12 bar max.

MATERIALES / CONSTRUCTION :

No.	Pieza Part	Material Material
1	Cuerpo Body	A.Inox CF8M S.Steel CF8M
2	Terminales Ends	A.Inox CF8M S.Steel CF8M
3	Bola Ball	A.Inox CF8M S.Steel CF8M
4	Asiento Seat	PTFE TFM 1600
5	Eje Stem	A.Inox AISI316 S.Steel 316
6	Asiento Eje Stem thrust seal	PTFE + 25% Glass
7	Junta Tórica Eje Stem O-Ring	FKM
8	Empaquetadura Gland Packing	Grafito Graphite
9	Prensa Gland	A.Inox AISI303 S.Steel 303
10	Anillo Elástico Elastic Ring	Inconel 718
11	Arandel Bloqueo Locking washer	A.Inox AISI304 S.Steel 304
12	Tuerca Prensa Gland Nut	A.Inox AISI303 S.Steel 303
12.1	Tuerca Palanca Handle Nut	A.Inox AISI303 S.Steel 303
13	Arandela Antifricción	PTFE + 25% Glass
14	Maneta Handle	A216 WCB
15	Tornillo Stud bolt	A 193 Gr B8M
16	Tuerca Nut	A 194 Gr 8M
17	Junta Espirometálica	SS 316L + PTFE + Graphite
18	Tornillo Bolt	A.Inox A2 S.Steel A2

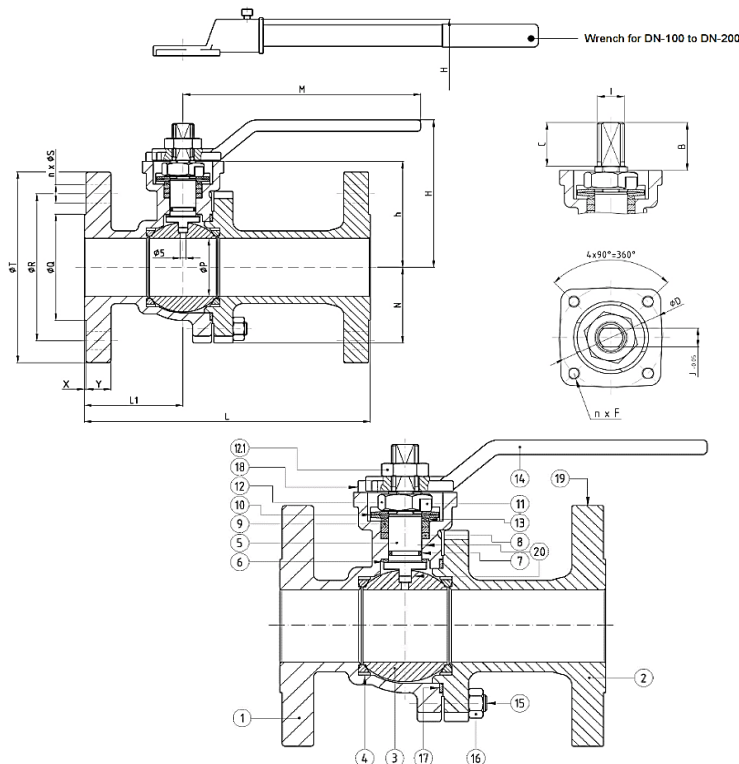

DIMENSIONES / DIMENSIONS :

DN ND	NPS	ØP	L	L1	M	H	N	ØQ	ØR	ØT	X	Y	h	B	C	J	I	ØD	N x F	ISO 5211	Torque Nm	Peso Weight
15	1/2"	15	108	47	170	68	31	35	60,45	88,9	2	9,6	41	18	11	7	M10	50	4 X M6	F05	6	1,70
20	3/4"	20	117	50	170	70	33	43	69,8	98,5	2	9,6	43	18	11	7	M10	50	4 X M6	F05	8	2,20
25	1"	25	127	52	170	86	39	51	79,24	108	2	9,6	58,5	22	21	8	M12	50	4 X M6	F05	12	2,90
40	1.1/2"	40	165	65	215	123	48	73	98,55	127	2	13	86,5	33	32	12	M18	70	4 X M8	F07	22	6,00
50	2"	50	178	61	215	128	63	92	120,7	152	2	14	91,5	33	32	12	M18	70	4 X M8	F07	36	8,50
65	2.1/2"	65	190	75	350	140	78	105	139,7	178	2	16	104	34	33	15	M22	70	4 X M8	F07	50	13,30
80	3"	78	203	79	450	190	87	127	152,4	191	2	17	119	34	33	15	M22	102	4 X M10	F10	79	18,50
100	4"	100	229	90	466	193	108	157	190,5	229	2	22	144	45	44	19	M28	102	4 X M10	F10	130	29,30
150	6"	151	394	174	775	259	152	216	241,3	280	2	24	203	56	55	24	M36	125	4 X M12	F12	220	64,50
200	8"	203	457	209	845	319	202	270	298,5	343	2	27	250	69	67	32	M48	140	4 X M16	F14	630	123,20