

VÁLVULAS DE BOLA / BALL VALVES

VÁLVULA DE BOLA ACERO CARBONO PN-16. BRIDAS DIN PN-16 2 PIECES BALL VALVE CAST STEEL NP16 FLANGED ENDS DIN NP16



VALVESEAL
valves & sealing solutions

TF-BVCS-F16-HP



FIRE SAFE
ISO 10497



UTILIZACIÓN / APPLICATION :

Aplicaciones en industrias químicas, petroquímicas, calefacción, agua, inst. hidráulicas, aire comprimido.
Chemical and petrochemical industries. Hydraulic installations. Heating, water distribution, compressed air.

CARACTERÍSTICAS GENERALES / GENERAL CHARACTERISTICS :

Paso total / Full Bore.
Eje anti-expulsión / Anti blow-out stem.
Montaje ISO 5211 / ISO 5211 Mounting pad.
Cuerpo de 2 piezas / Split body type.
Dispositivo antiestático / Anti Static device.

NORMATIVAS / STANDARDS :

Fabricación / Manufacture according to ISO 9001:2015.
Diseño / Design according to EN 1983-ISO 17292.
Marcado / Marking according to EN 19.
Directiva CE / Directive 2014/68/EU: CE No. 0035 Risk Category III Module H.
Pruebas de presión / Pressure Tests according to EN 12266-1 Rate A.
Bridas RF / RF Flanged ends according to EN 1092-1 PN16.

CONDICIONES DE SERVICIO / WORKING CONDITIONS :

Máxima presión de trabajo / Maximum Working Pressure : 40 bar hasta DN50, 16 bar desde DN65.
Temperatura máxima de trabajo / Maximum Working Temperature : - 20 °C / + 230 °C.
Vacío / Vacuum : 10² torr.
Aire comprimido (Temp. Ambiente) / Compressed Air (Ambient temp.) : 8 bars maximum.
Vapor / Steam : 12 bars maximum.



MATERIALES / CONSTRUCTION :

No.	Pieza Part	Material Material
1	Cuerpo Body	A216 WCB
2	Terminales Ends	A216 WCB
3	Bola Ball	A.Inox CF8M (316) S.Steel CF8M (316)
4 *	Asiento Seat	Pure PTFE TFM 1600
5	Eje Stem	A.Inox AISI316 S.Steel 316
6 *	Junta Eje Stem thrust seal	PTFE + 25% Glass
7 *	Junta Tórica Eje Stem O'ring	FKM
8 *	Empaquetadura Gland Packing	Graphite
9	Junta Tórica O ring	FKM
9	Prensa Gland	A.Inox AISI303 S.Steel 303
10	Anillo Elástico Elastic Ring	Inconel 718
12	Tuerca Prensa Gland nut	A.Inox AISI303 S.Steel 303
12,1	Tuerca Palanca Handle Nut	A.Inox AISI303 S.Steel 303
13	Arandela anti-fricción Antifriction washer	PTFE + 25% Glass
14	Maneta Handle	Fundición Dúctil Nodular Iron
15	Perno Stud	A 193 Gr.B7M
16	Tuerca Nut	A 194 Gr.2HM
17 *	Espirometálica Spiral wound gasket	SS316L + PTFE + Graphite
18	Tornillo Bolt	A2

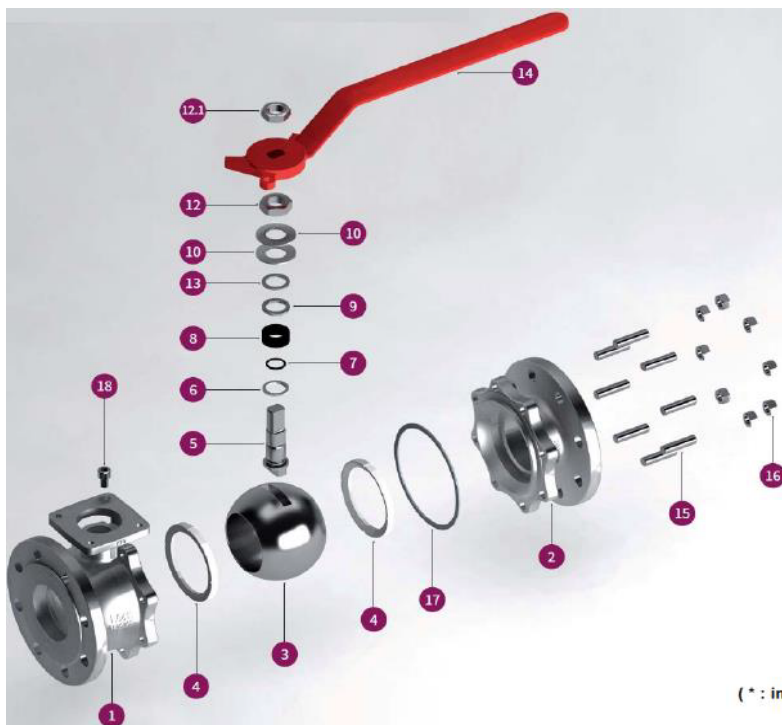

(* : included in gaskets kit)

Las especificaciones del producto están sujetas a modificaciones sin previo aviso. The specifications of the presented products are open to modifications without previous advice.

VÁLVULAS DE BOLA / BALL VALVES

VÁLVULA DE BOLA ACERO CARBONO PN-16. BRIDAS DIN PN-16
2 PIECES BALL VALVE CAST STEEL NP16 FLANGED ENDS DIN NP16



VALVESEAL
valves & sealing solutions

TF-BVCS-F16-HP



FIRE SAFE
ISO 10497

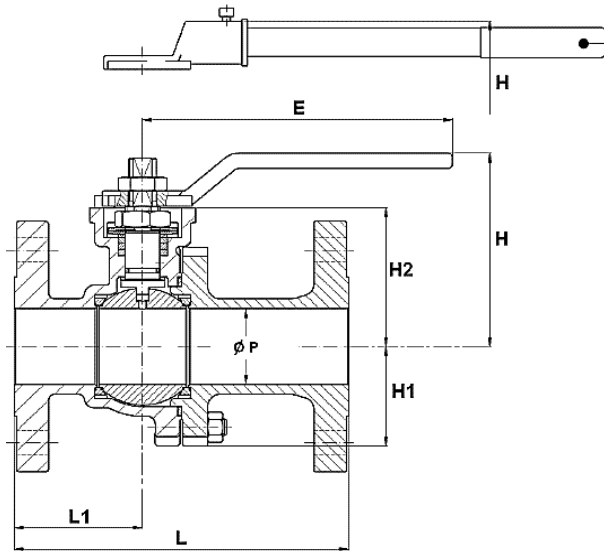

ISO 5211 Y EJE / ISO MOUNTING PAD & STEM SIZE:

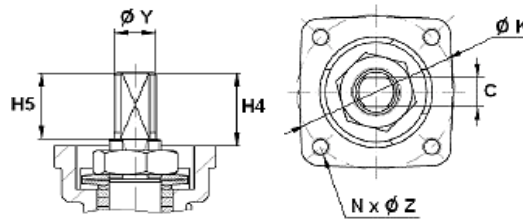

DIMENSIONES / DIMENSIONS:

DN ND	ØP	L	L1	E	H	H1	H2	H4	H5	C	ØY	ØK	N x ØZ	ISO 5211	Par Torque Nm	Peso Weight
15	15	115	53	170	68	31	41	18	11	7	M10	50	4 X M6	F 05	8	2,40
20	20	120	52	170	70	33	43	18	11	7	M10	50	4 X M6	F 05	12	3,20
25	25	125	52	170	86	39	58,5	22	21	8	M12	50	4 X M6	F 05	14	4,10
32	32	130	54	170	89,5	43	63,5	22	21	8	M12	50	4 X M6	F 05	22	5,80
40	40	140	55	215	123	48	86,5	33	32	12	M18	70	4 X M8	F 07	27	8,10
50	50	150	61	215	128	63	91,5	33	32	12	M18	70	4 X M8	F 07	50	10,60
65	65	170	72	335	140	78	104	34	33	15	M22	70	4 X M8	F 07	51	13,30
80	78	180	73	430	190	87	119	34	33	15	M22	102	4 X M10	F 10	77	19,10
100	100	190	83	466	193	108	144	45	43,5	19	M28	102	4 X M10	F 10	116	25,60
125	125	325	120	680	240	134	184	56	54,5	24	M36	125	4 X M12	F 12	159	47,60
150	151	350	135	680	259	152	203	56	54,5	24	M36	125	4 X M12	F 12	215	63,50
200	203	400	200	845	319	202	250	69	67	32	M48	140	4 X M16	F 14	493	115,30

DIAGRAMA PRESIÓN-TEMPERATURA (VAPOR EXCLUIDO) / PRESSURE-TEMPERATURE CHART (STEAM EXCLUDED):

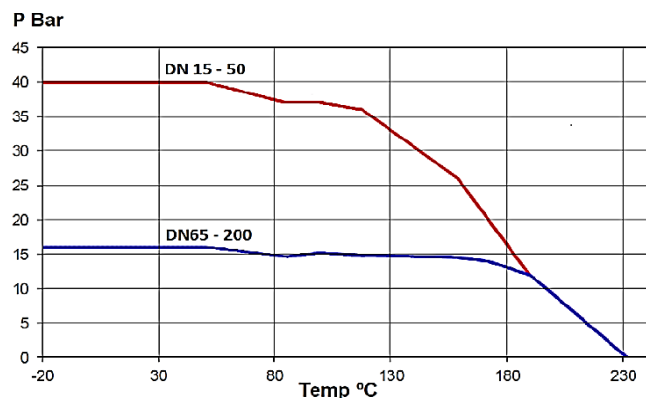

The specifications of the presented products are open to modifications without previous advice.

Las especificaciones del producto están sujetas a modificaciones sin previo aviso.