

VÁLVULAS DE BOLA / BALL VALVES

VÁLVULA DE BOLA ALTAS PRESTACIONES. A.INOX PN-40. BRIDAS DIN PN-40 2 PIECES HIGH PERFORMANCE BALL VALVE S.STEEL. PN40. FLANGED DIN PN40



VALVESEAL
valves & sealing solutions

TF-BVSS-F40-HP



UTILIZACIÓN / APPLICATION :

Aplicaciones en industrias químicas, petroquímicas, calefacción, agua, inst. hidráulicas, aire comprimido.
Chemical and petrochemical industries. Hydraulic installations. Heating, water distribution, compressed air.

CARACTERÍSTICAS GENERALES / GENERAL CHARACTERISTICS :

Paso total / Full Bore.
Eje anti-expulsión / Anti blow-out stem.
Montaje ISO 5211 / ISO 5211 Mounting pad.
Cuerpo de 2 piezas / Split body type.
Dispositivo antiestático / Anti Static device.

NORMATIVAS / STANDARDS :

Fabricación / Manufacture according to ISO 9001:2015.
Diseño / Design according to EN 1983-ISO 17292.
Marcado / Marking according to EN 19.
Directiva CE / Directive 2014/68/EU: CE No. 0035 Risk Category III Module H.
Pruebas de presión / Pressure Tests according to EN 12266-1 Rate A.
Bridas RF / RF Flanged ends according to EN 1092-1 PN40.
Fire safe according to ISO 10497 : 2004
Fugitive Emissions according to EN 15848-1 : 2006
ATEX Group II Category 2 G/2Dc Zone 1 & 21 Zone 2 & 22 according to directive 2014/34/EU

CONDICIONES DE SERVICIO / WORKING CONDITIONS :

Máxima presión de trabajo / Maximum Working Pressure : 40 bar
Temperatura máxima de trabajo / Maximum Working Temperature : - 20 °C / + 230 °C.
Vacío / Vacuum : 10² torr.
Aire comprimido (Temp. Ambiente) / Compressed Air (Ambient temp.) : 8 bars maximum.
Vapor / Steam : 12 bars maximum.

MATERIALES / CONSTRUCTION :

No.	Pieza Part	Material Material
1	Cuerpo Body	A.Inox EN 1.4408 S.Steel EN 1.4408
2	Terminales Ends	A.Inox EN 1.4408 S.Steel EN 1.4408
3	Bola Ball	A.Inox CF8M (316) S.Steel CF8M (316)
4 *	Asiento Seat	Pure PTFE TFM 1600
5	Eje Stem	A.Inox AISI316 S.Steel 316
6 *	Junta Eje Stem thrust seal	PTFE + 25% Glass
7 *	Junta Tórica Eje Stem O'ring	FKM
8 *	Empaquetadura Gland Packing	Graphite
9	Junta Tórica O ring	FKM
9	Prensa Gland	A.Inox AISI303 S.Steel 303
10	Anillo Elástico Elastic Ring	Inconel 718
12	Tuerca Prensa Gland nut	A.Inox AISI303 S.Steel 303
12,1	Tuerca Palanca Handle Nut	A.Inox AISI303 S.Steel 303
13	Arandela anti-fricción Antifriction washer	PTFE + 25% Glass
14	Maneta Handle	Fundición Dúctil Nodular Iron
15	Perno Stud	A 193 Gr.B8M
16	Tuerca Nut	A 194 Gr.8M
17 *	Espirometálica Spiral wound gasket	SS316L + PTFE + Graphite
18	Tornillo Bolt	A2

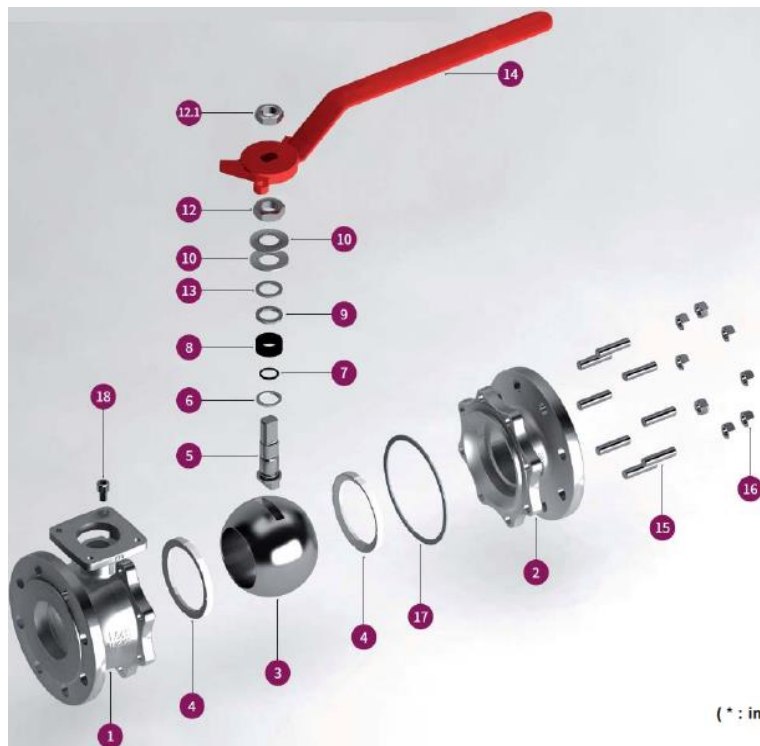

(* : included in gaskets kit)

Las especificaciones del producto están sujetas a modificaciones sin previo aviso. The specifications of the presented products are open to modifications without previous advice.

VÁLVULAS DE BOLA / BALL VALVES

VÁLVULA DE BOLA ALTAS PRESTACIONES. A.INOX PN-40. BRIDAS DIN PN-40
2 PIECES HIGH PERFORMANCE BALL VALVE S.STEEL. PN40. FLANGED DIN PN40



VALVESEAL
valves & sealing solutions

TF-BVSS-F40-HP

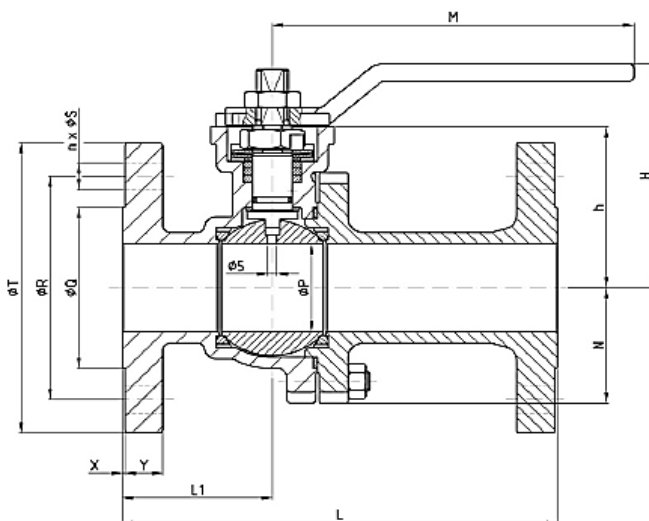

ISO 5211 Y EJE / ISO MOUNTING PAD & STEM SIZE:

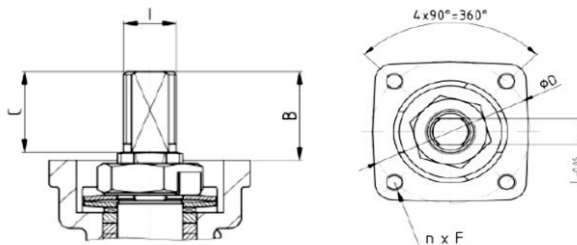

DIMENSIONES / DIMENSIONS :

DN ND	ØP	L	L1	ØQ	ØR	n x ØS	ØT	X	Y	h	N	H	M	B	C	J	I	ØK	n x F	ISO 5211	Par Torque Nm	Peso Weight
15	15	115	53	45	65	4x14	95	2	14	41	31	68	170	18	11	7	M10	50	4 X M6	F 05	8	2,40
20	20	120	52	58	75	4x14	105	2	16	43	33	70	170	18	11	7	M10	50	4 X M6	F 05	12	3,20
25	25	125	52	68	85	4x14	115	2	16	58,5	39	86	170	22	21	8	M12	50	4 X M6	F 05	14	4,10
32	32	130	54	78	100	4x18	140	2	16	63,5	43	89,5	170	22	21	8	M12	50	4 X M6	F 05	22	5,80
40	40	140	55	88	110	4x18	150	2	16	86,5	48	123	215	33	32	12	M18	70	4 X M8	F 07	27	8,10
50	50	150	61	102	125	4x18	165	2	18	91,5	63	128	215	33	32	12	M18	70	4 X M8	F 07	50	10,60
65	65	170	72	122	145	8x18	185	2	20	104	78	140	350	34	33	15	M22	70	4 X M8	F 07	74	14,80
80	78	180	73	138	160	8x18	200	2	22	119	87	190	450	34	33	15	M22	102	4 X M10	F 10	118	20,60
100	100	190	83	158	190	8x22	235	2	22	144	108	193	466	45	43,5	19	M28	102	4 X M10	F 10	136	29,20
125	125	325	120	188	220	8x26	270	2	24	184	134	240	775	56	54,5	24	M36	125	4 X M12	F 12	204	53,60
150	151	350	135	212	250	8x26	300	2	26	203	152	259	775	56	54,5	24	M36	125	4 X M12	F 12	408	74,70

DIAGRAMA PRESIÓN-TEMPERATURA (VAPOR EXCLUIDO) / PRESSURE-TEMPERATURE CHART (STEAM EXCLUDED):

